

**ExDetector
HC-100**

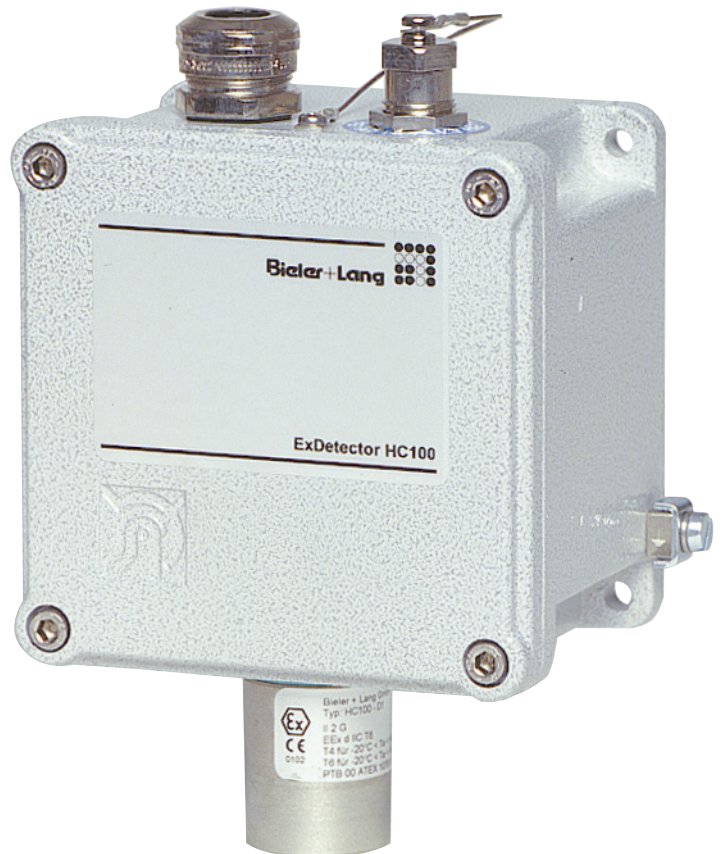

Data Sheet

Gas Measuring and Alarm Systems



Application / Construction

The ExDetector HC100 series of measuring probes, used in conjunction with evaluation systems, have the following functions:

- Measurement and indication of the actual concentration of potentially explosive gases and vapours
- Monitoring and warning of these gases
- Triggering of safety measures
 - Technical: the rise in concentration is counteracted by control actions (fans, disconnections, etc.)
 - Organisational: visual and audible signals.

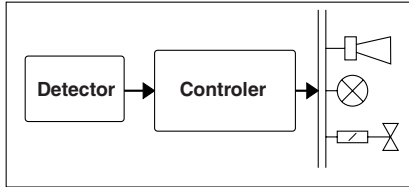

A gas warning system consists of the following components:

- probe
- evaluation system
- controllable devices such as fans, warning screens and solenoid valves

Product features

- detection of combustible gases and vapours
- measuring range: 0 - 100 % LEL
- measuring principle: catalytic combustion
- linear measuring signal 4 - 20 mA
- one-man calibration (optional operating unit)
- ATEX-conformity for applications in hazardous areas zone 1 and 2
- 3-wire technology
 - 24 V DC
 - 4 - 20 mA
 - ground
- types:
 - **HC100-M**: standard for wall mounting

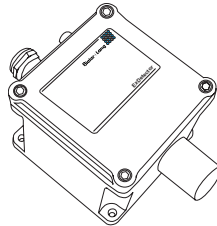

- **HC100-T / HC100-K**:
with separate transmitter for mounting in ventilation ducts

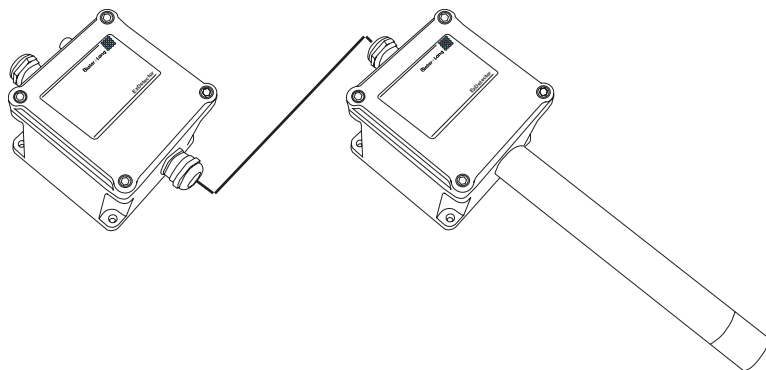

Operating principle

The probe electronics control the operating parameters (heater voltage) of the sensor. The sensor consists of an active and an inactive element. The inactive sensor element is connected in a Wheatstone bridge circuit with the active element and compensates for environmental effects such as variations in ambient temperature. As soon as combustible gas reaches the active sensor, the sample gas is burned. The heat produced in the reaction changes the electrical resistance value and hence the bridge signal. These small voltage signals are processed and then converted to a 4 - 20 mA measurement signal. Operating parameters are programmed and the measuring element adjusted using the operating unit, which is also explosion protected, available as an option. This facilitates operation and maintenance, even in the hazardous area.

Block diagram

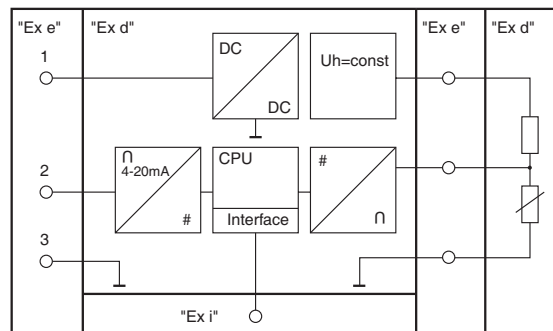

Technical data (gases)

	ExDetector HC100- M	ExDetector HC 100-T ExDetector HC 100-K
Areas of use	Zone 1 and 2 hazardous areas	
Device category	II 2G	
Application	Wall-mounting	Duct-mounting
Detectable gases	Combustible gases and vapours 1) List of the examined gases / vapours see EC-Type-Examination BAM 03 ATEX 0003X	
Range	0 - 100 % LEL in air Oxygen in measuring gas 10 ... 20,9 vol%	
Measurement principle	Catalytic combustion	
Response time T90	Dependent on sample gas (10 ... 60 sec)	
Warm-up time	10 sec	
Max. flow velocity	15 m/sec (BAM examined to 6 m/sec)	
Temperature range	-20 °C to +55°C	ExDetector HC 100-T: -20°C to +55°C ExDetector HC 100-K: Housing: -20°C to +55°C Sensor: -20°C to +80°C
Atmospheric pressure range	800 - 1100 hPa	
Humidity range	20 - 90 % rH	
Storage terms	Temperature: -25°C to 60°C Pressure: 800 hPa to 1100 hPa Humidity: 20% r.F. to 90% rH	

1) The service life of a catalytic combustion sensor is affected by so-called catalyst poisons. These poisonous substances include compounds of sulphur, phosphorus, silicon and lead. The anticipated service life of > 3 years is also reduced by corrosive substances which release fluorine and chlorine compounds in the course of the reaction at the measuring element.

**Technical data
(installation)**

	ExDetector HC100-M	ExDetector HC 100-T ExDetector HC 100-K
Field interface	4 - 20 mA, max load 350 Ohm	
Supply voltage (probe terminal)	18 - 32 V DC SELV / PELV max 5.5 W pre-fuse 100 mA anti-surge	ExDetector HC 100-T: 18 - 32 V DC SELV / PELV max 5.5 W pre-fuse 100 mA anti-surge ExDetector HC 100-K: only for connection to the specified interface of the ExDetector HC 100-T Pmax = 1.6 W Umax = 12 V DC Imax = 0.5 A DC
Calibration interface	Ignition protection type Ex ib IIC; only for connection to a certified intrinsically safe circuit: Ui = 13.8 V / Pi = 432 mW / Li = 0 / Ci = 0	
Safety maximum voltage	Um = 250 V	
Max. cable length	1000 m depending on the cable type	1000 m depending on the cable type Connecting lead HC 100-T / HC 100-K: 3 m / 1.5 mm ² / screened
Connecting cable	3 active cores, cable screened preferably H05VVC4V5-K	
Suitable evaluation instruments	Gasmesscomputer 8022, GMC 8022E, GMC 8364, GMC 8420	
EC-Type-Examination Directive 2014/34/EU electrical safety	Housing/electronics: II 2G Ex de [ib] IIC T6 Gb PTB 00 ATEX 1075 -20°C < TA < +55°C	ExDetector HC 100-T: Housing/electronics: II 2G Ex de [ib] IIC T6 Gb PTB 00 ATEX 1075 -20°C < TA < +55°C ExDetector HC 100-K: Housing: II 2G Ex de IIC T6 Gb PTB 00 ATEX 1075 -20°C < TA < +55°C
	Measuring head: II 2G Ex d IIC Gb T4 für -20°C < TA < 80°C T6 für -20°C < TA < 55°C	

Mechanical data

	ExDetector HC 100-M	ExDetector HC 100-T ExDetector HC 100-K
Protection (housing)	IP54	
Housing material	Sensor: stainless steel Housing: aluminium	
Weight	approx. 1300 g	HC 100-T: approx. 1200 g HC 100-K: approx. 1500 g
Cable entry	Cable diameters 8 - 13 mm	
Terminals	3-way 0.5 - 1.5 mm ²	

Mechanical data

- ExDetector HC 100-M

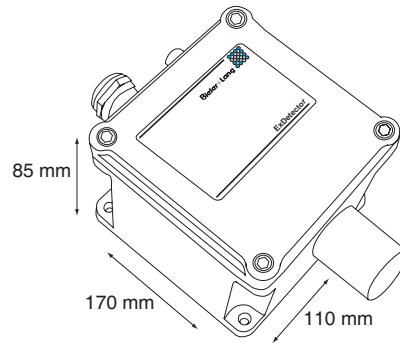

- ExDetector HC 100-T

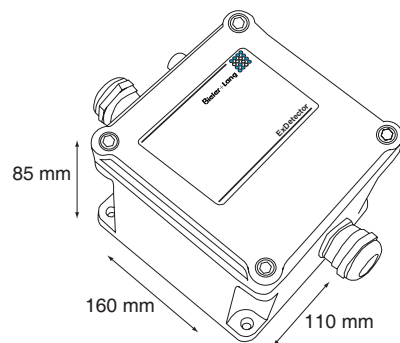

- ExDetector HC 100-K

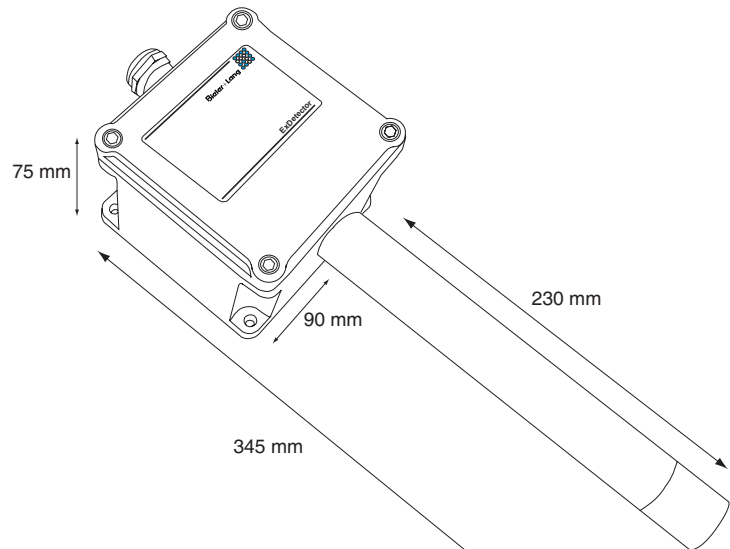

- Flange

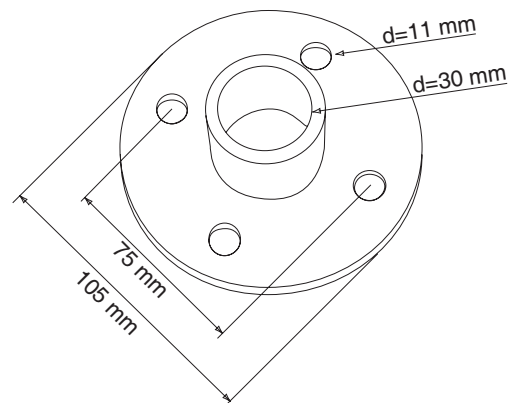

**Certification**

- EC-Type-Examination Directive 2014/34/EU
 - Housing/electronics (ExDetector HC 100-M / -T):
 - II 2G
 - Ex de [ib] IIC T6 Gb
 - PTB 00 ATEX 1075
 - Housing (ExDetector HC 100-K):
 - II 2G
 - Ex de IIC T6 Gb
 - PTB 00 ATEX 1075
 - Sensor:
 - II 2G / Ex d IIC Gb
 - T4 for $-20^{\circ}\text{C} < \text{TA} < +80^{\circ}\text{C}$
 - T6 for $-20^{\circ}\text{C} < \text{TA} < +55^{\circ}\text{C}$
 - PTB 00 ATEX 1076U
 - Performance certification: BAM 02 ATEX 0003 X
-

Instrument safety

For authorised use of the HC100 in Zone 1 and 2 hazardous areas, compliance with the following standard ensures the highest instrument safety:

- EN 50270 (product standard)
 - Electromagnetic compatibility of electrical apparatus for the detection and measurement of combustible gases, toxic gases or oxygen
-

Accessories

- test gas set
 - calibration gases
 - operating unit type Calibrationbox-I
-

Service

Everything from one single source - from design to installation of your new gas warning system. This is guaranteed by our comprehensive sales and service network. Please ask about the personal contact for your region. Our service technicians are also available for after-sales support and advice.

Bieler + Lang GmbH
Gas Detection and Warning Systems

Von-Drais-Str. 31, D-77855 Achern

Telephone +49 (0) 78 41 / 69 37 - 0
Telefax +49 (0) 78 41 / 69 37 - 99
E-Mail info@bieler-lang.de

Internet www.bieler-lang.de

Technical status: 02/2020
Technical modifications possible!
